



## F68/326 - IMC Vulture 826 Free-standing Food Waste Disposer - 3 Phase [ 4 wire ][ air break ] - W 430 mm - 2.2 kW

Reliable, efficient, safe and easy to operate, the 826 Waste Disposer allows operators to quickly and effectively remove waste, to create a safer and cleaner kitchen.

- ✓ Fast and efficient disposal of up to 600kg of food waste per hour.
- ✓ Manually reversible motor to extend operational life.
- ✓ Handles up to 1350 covers per sitting - ideal for large kitchens.
- ✓ With class A airbreak kit - recommended when connecting to a mains water supply.
- ✓ For tough waste (red meat bones, cauliflower stalks and fish skins).
- ✓ Suitable for large kitchens with three-phase, four-wire power supply.
- ✓ Compact, free-standing design, for quick and easy loading.

### Specifications

#### Summary

<b>Brand</b>	IMC
<b>Range</b>	Vulture
<b>Series</b>	800 Series
<b>Power Type</b>	Electric
<b>Unit Type</b>	Free-standing
<b>Available in UK Only</b>	No
<b>UK Warranty</b>	2 Years Parts and Labour Warranty
<b>Export Warranty</b>	Contact your local dealer
<b>Mounting</b>	Free-standing
<b>GTIN</b>	5056105199311

#### Power and Performance

<b>Total Power kW</b>	2.2
<b>HP</b>	3
<b>IP Rating</b>	IP55

#### Key Specifications

<b>Operator Safety</b>	Interlocks
<b>WRAS Approved</b>	WRAS Compliant
<b>Airbreak</b>	Yes

#### Capacity

<b>Type of Waste</b>	Tough waste
<b>Covers Per Sitting</b>	1350
<b>Capacity Kg per Hour</b>	600

#### Weights and Dimensions

<b>Unit Height (External) mm</b>	980
<b>Unit Width (External) mm</b>	430
<b>Unit Depth (External) mm</b>	600
<b>Net Weight Kg</b>	64.5

#### Supply Connections

<b>Requires Installation</b>	Yes
<b>Requires Electrical Supply</b>	Yes
<b>UK 3 Pin Plug</b>	No
<b>Requires Hardwiring</b>	Yes
<b>Electrical Supply Rating Watts</b>	2200
<b>Three Phase Amps</b>	5.3
<b>Three Phase Voltage</b>	400
<b>Water Supplied From</b>	Mains or storage cistern
<b>Water Connection Pressure Bar</b>	0.4
<b>Drain Connection</b>	40mm Pipe with P or S trap; MIN fall = 1/7
<b>Water Connection</b>	15mm

## Shipping

<b>Packed Weight Kg</b>	70.95
<b>Packed Height cm</b>	104
<b>Packed Width cm</b>	63
<b>Packed Depth cm</b>	48

## Available Options

### SIDE PANEL

**E68/013** 826 SIDE PANEL

### MAG CUTLERY SAVER

**VS167** 700/800/904/904X MAGNETIC CUTLERY SAVER

### REMOTE CONTROL BOX

**VS258** 825 DUMP STATION/826 REMOTE CONTROL BOX

### WATER FLOW CONTROL

**VS358** 826 WATER FLOW CONTROL

## Technical Picture

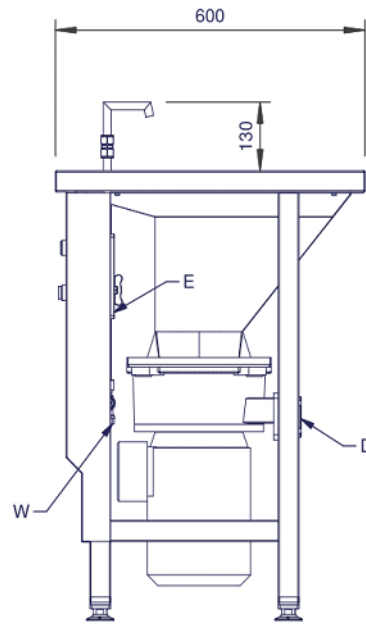
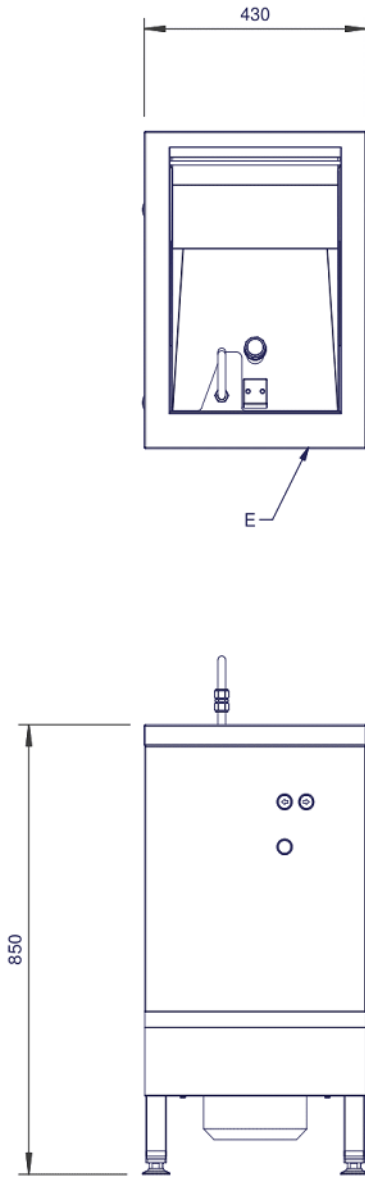

**Lincat Limited**

Whisby Road,  
Lincoln, LN6 3QZ,  
United Kingdom

**Company No:** 2175448

A member company of



**Customer Care**

**Tel:** +44 1522 875500

**Email:** care@lincat.co.uk

**Export Customers**

**Tel:** +44 1522 875536

**Email:** export@lincat.co.uk

**Opening Hours**

**Monday – Friday:**

8.30am – 5pm