



# HAND BLENDER XM-33

Professional immersion blender. 400 W.



- ✓ Professional performance: capable of carrying out prolonged work without the casing overheating.
- ✓ Life-plus: equipped with a motor which has passed all of the most demanding usage tests.
- ✓ Studied geometry: casing designed to avoid rolling and falling.
- ✓ Easy to clean: detachable arm, can be cleaned under the tap.
- ✓ Approved by NSF: guaranteed safety and hygiene.

## INCLUDES

- ✓ Fixed speed motor block.
- ✓ MA-33 mixer arm.
- ✓ Wall mount.

## ACCESSORIES

- Clamp sliding frame
- Bowl clamp
- Mixer arms MA-30

## SALES DESCRIPTION

Fixed speed motor block.  
420 mm detachable arm.  
Designed for continuous use in recipients of up to 60 litres.

### All-in-one

- ✓ Professional hand blender designed for carrying out different preparations without the need for add-on tools.
- ✓ Professional Y-blade, made from tempered steel and with a long-duration cutting edge.
- ✓ Fixed speed.
- ✓ Designed to work in recipients of up to 60 litres.

### Maximum comfort for the user

- ✓ Compact design: logical and manageable size.
- ✓ Ergo-design & bi-mat-grip: external casing made in two materials for an ergonomic hold. Anti-slip grip. Optimum inclination of handle, minimising fatigue.
- ✓ Click-on-arm: detachable arm with fast and secure closure.
- ✓ Hood designed to avoid splashes.
- ✓ Intuitive use: very simple operation. LED warning light in two colours to indicate the status of the machine.
- ✓ Possibility of continuous operation.

### Built to last



**sammic** | [www.sammic.com](http://www.sammic.com)  
Food Service Equipment Manufacturer

Polígono Basarte, 1. phone +34 943 15 72 36  
20720 Azkoitia, Spain [sales@sammic.com](mailto:sales@sammic.com)



Project	Date
Item	Qty
Approved	

DYNAMIC PREPARATION  
COMMERCIAL HAND BLENDERS - XM RANGE

product sheet  
updated 29/03/2021



# HAND BLENDER XM-33

Professional immersion blender. 400 W.



## SPECIFICATIONS

Total loading: 400 W  
Maximum recipient capacity: 60 l  
Maximum working depth: 283.3 mm  
Motor speed: 12000 rpm  
Blade diameter: 55 mm  
Blade guard diameter: 92.2 mm

### Length

Liquidising arm length: 420 mm  
Total length: 728 mm  
Net weight: 3.74 Kg  
Noise level (1m.): <80 dB(A)

### Crated dimensions

455 x 475 x 117 mm  
Gross weight: 4.73 Kg.

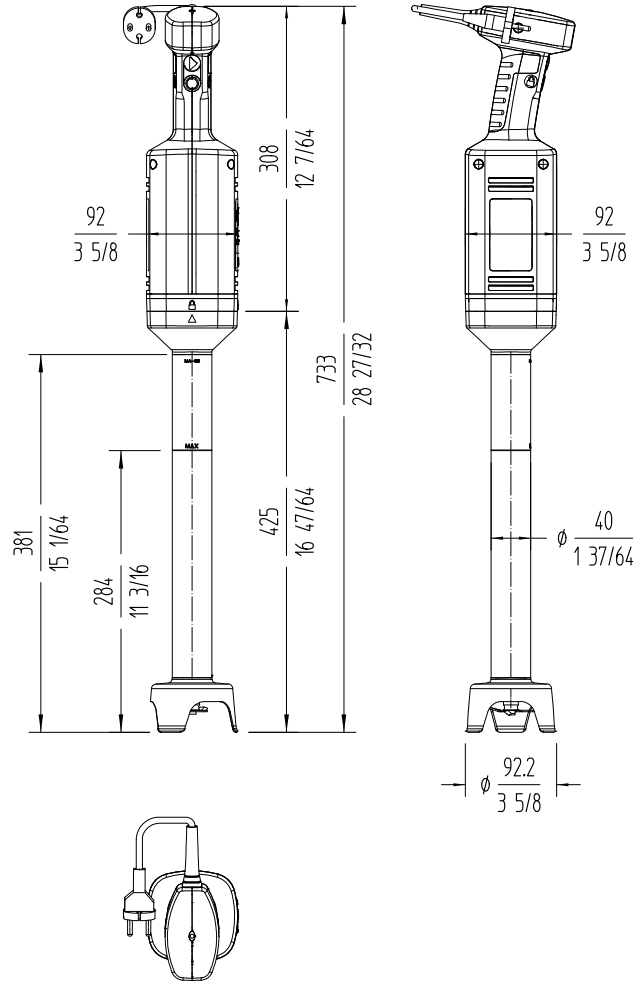

DYNAMIC PREPARATION  
COMMERCIAL HAND BLENDERS - XM RANGE

## AVAILABLE MODELS

3030675 Immersion blender XM-33 230/50-60/1

\* Ask for special versions availability

**sammic** | www.sammic.com  
Food Service Equipment Manufacturer

Polígono Basarte, 1. phone +34 943 15 72 36  
20720 Azkoitia, Spain sales@sammic.com



Project	Date
Item	Qty
Approved	

product sheet  
updated 29/03/2021