

MODELS: AN501SC AN1002SC *Seasoning refrigerator. AN500/100L series.*



Strengths

- ✓ *New efficient line of seasoning refrigerators improved in design, robustness and maintaining the same capacity and high standards of quality and reliability, for keeping improving the energy class.*
- ✓ *New design double handle door for ease of use. In addition, they are equipped with hinges for automatic return and permanent pressure during closing. The automatic return is free when the opening exceeds 95°. Includes "cleanless" four-chamber door gasket easily removable.*
- ✓ *The new easy-use controller has a greater precision in the control of the temperature. Easier to adjust the temperature range we want to achieve.*
- ✓ *All condenser units are tested 100%, in helium chambers to refrigerant leak detections.*
- ✓ *LED lighting incorporated, reducing energetic consumption between 80% and 90% respect to a traditional light bulb. Lighting in all levels and in the front to highlight the products.*
- ✓ *Infrico is AENOR audited and certified by internationally recognized firm. ISO 9001:2015 (Quality); ISO 14001:2015 (Environmental); OSHAS 18001:2007 (Prevention and Worker Safety). Audited and Certified by INTERTEK for compliance with UL 471 and NSF 7.*

Revision: 01 Fecha: 06/08/2018 AN501SC, AN1002SC, FT, Es.0.1

MODELS	Dimensions (mm)			No Doors	Bars for meat set	Cabinet volume (L)	Gross volume (L)	Humidity control	Temperature regime (°C)	Ref.	Gas charge (gr.)	Net weight (Kg)
	Length	Depth	Height place									
AN501SC	687	700	2060	1	3	500	990	40-55 %	+4°C / +16°C	R134a	240	103
AN1002SC	1385	700	2060	2	6	1110	1997	40-55 %	+4°C / +16°C	R134a	280	189

WE RESERVE THE RIGHT TO CHANGE SPECIFICATIONS WITHOUT PRIOR NOTICE

MODELS: AN501SC AN1002SC *Seasoning refrigerator. AN500/100L series.*

STANDARD CHARACTERISTICS

➤ **Concept**

- Heating and seasoning reach ins, with inner heater resistors, ideal for sausage production instalations.

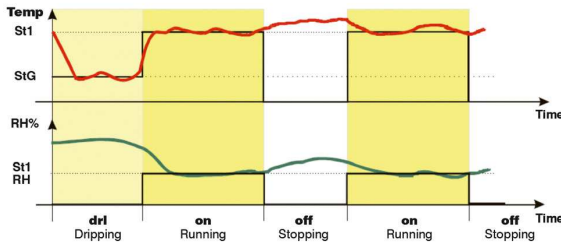

➤ **Exterior**

- AISI 304 Stainless Steel,
- Back of galvanized metal plate,
- Adjustable legs up to 200 mm.

➤ **Interior**

- AISI 304 Stainless Steel,
- Wide rounded corners to aid cleaning,
- Drain inside the cabinet,
- LED lighting.
- Bars for meat included.



OPTIONAL

- Set of slides.
- Lock.
- Meat bar set.
- Glass door.
- Electrical connection 220 V / 1 ph / 60 Hz,
- Electrical connection 115 V / 1 ph / 60 Hz.

➤ **Insulation**

- Insulation by free CFC's polyurethane of thickness 55 mm, foam high-pressure injected with density 40 Kg/m³.
- Zero ODP and Low GWP.

➤ **Doors**

- Doors with integrated double handle and blocked opening hinge.
- Interior of door inserted with a "cleanless" four-chamber door gasket easy to remove.
- Door opening of 580x1345 mm,

➤ **Refrigeration**

- Temperature and defrost regulated by a digital controller.
- Temperature and humidity electronic control.
- Discontinuous seasoning cycle.
- Ventilated cooling system.
- Forced evaporation system.
- Energy-saving non-electric condensate pan,
- Evaporators treated with anti-corrosion polyester Epoxy.
- Climatic class 4 (30°C, 55%RH).

➤ **Electrical**

- Electrical connection: 230 V / 1 ph / 50 Hz 

MODELS	Dimensions palletizing (mm)			Pallet weight (Kg.)	Comp. (HP)	Power (W)	Cooling power (W a -10°C)	Consumption (kWh/24h)	Intens. (A)	Container 20' / 40' / 40' HC	Trailer
	Length	Depth	Height place								
AN501SC	800	780	2100	115	1/4	1250	298	4,80	5,88	14 / 30 / 30	51
AN1002SC	1480	780	2100	209	3/8	1670	464	6,41	6,07	10 / 23 / 23	27

WE RESERVE THE RIGHT TO CHANGE SPECIFICATIONS WITHOUT PRIOR NOTICE



Infrico
 Ctra. de Aguilar A-318 por Moriles
 km. 15,5 - A-3132
 14900 Lucena (Córdoba)
 Spain

www.infrico.com
 info@infrico.com
 Tel. 00 34 957 51 03 03
 Fax. 00 34 957 51 03 04

APPROVALS: _____ **AVAILABLE AT:** _____



MODELS: AN501SC AN1002SC *Seasoning refrigerator. AN500/100L series.*

GENERAL VIEW

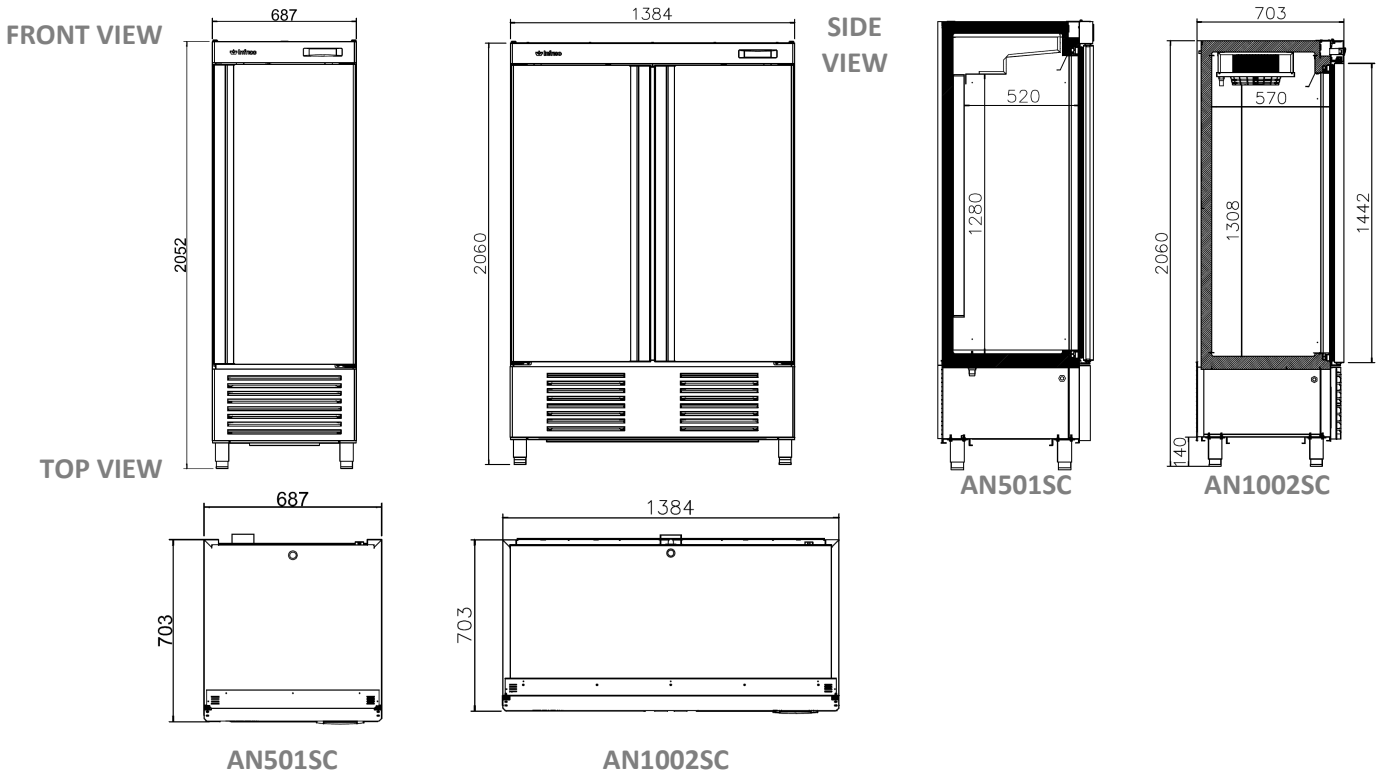

CONNECTIONS

MODELS	A (mm)	B (mm)	C (mm)	D (mm)	E (mm)
AN501SC	156	345	431	2016	90
AN1002SC	177	692	431	2016	124

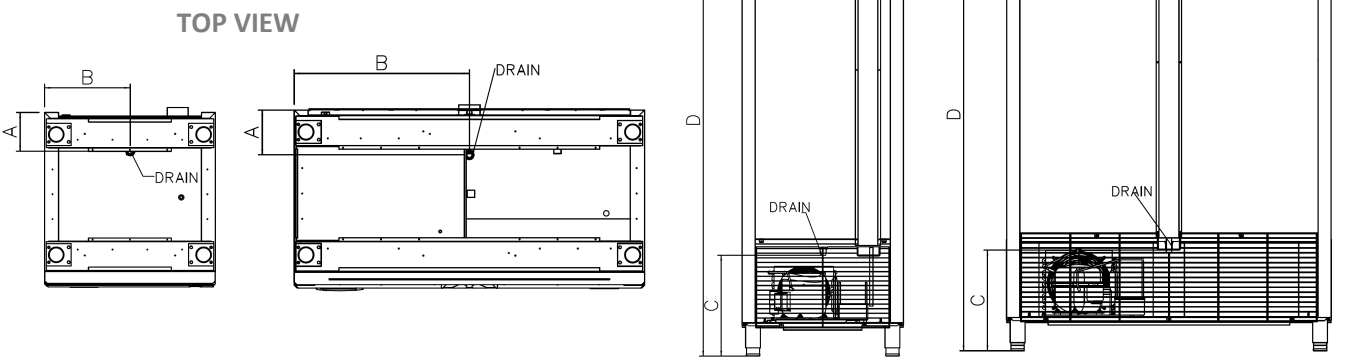

Revision: 01 Fecha: 06/08/2018 AN501SC, AN1002SC_FT_Es.0.1

WE RESERVE THE RIGHT TO CHANGE SPECIFICATIONS WITHOUT PRIOR NOTICE