



IMC IMCLEAN MOBILE HAND WASH STATION WITH SPLASHBACK, SOAP & PAPER TOWEL HOLDER - W 450MM - 3.0KW

MODEL: F63/501



Designed for locations where mains water supply is unavailable, the Mobile Hand Wash Station is an invaluable unit for organisations looking to increase hygiene and safety standards.

The station holds 10 litres of water per fill, enough for 85 hand washes. Easy to use, users simply fill the unit with water and plug it in. A foot-activated, infra-red operated tap dispenses water hygienically with no need for hand contact, with the temperature limited to 42°C for safety. An internal waste collection receptacle holds the dirty water.

The sturdy, stainless steel unit comes with an integrated splash back and a built-in soap holder

PRODUCT OPTIONS AND ACCESSORIES

- S63/222 Bin Bag Holder for Mobile Hand Wash Station [inc. 20 x Bin Bags]
- S63/223 Bin Bags for Mobile Hand Wash Station [Pk 20] [fits S63/222 Holder]

PRODUCT FEATURES

- Provides hand washing facility in locations where mains water isn't available.
- Ideal for increasing hygienic hand washing facilities wherever required - just fill, plug in and go.
- Provides 85 hand washes - 10 litres per fill.
- Internal waste collection - no need for drainage.
- Water temperature limited to 42°C for user safety.
- Foot-activated, infrared-operated tap make unit hygienic, with no need for hand contact.
- Large wheels make hand wash station quick and easy to move.
- Constructed from sturdy and hygienic stainless steel, including handy accessories, making it easy to wipe clean.

A/A FILE NUMBER:

ITEM NUMBER:



IMC IMCLEAN MOBILE HAND WASH STATION WITH SPLASHBACK, SOAP & PAPER TOWEL HOLDER - W 450MM - 3.0KW

MODEL: F63/501

WEIGHTS & DIMENSIONS

Width	450 mil
Depth	543 mil
Height	1250 mil
Weight	32 kg

SHIPPING DETAILS

Ship Width	68 cm
Ship Depth	57 cm
Ship Height	160 cm
Ship Weight	35.2 kg
Number of Shipment Parcels	1
Ship Method	Small Parcel (FedEx, UPS, DHL)
Shipping Package Type	Pieces
Shipping Origin Zip Code	LN6 3QZ, UNITED KINGDOM
Quick Ship Product	No

WATER, PLUMBING, AND DRAINAGE SPECS

Water Line Required	No
Drain Line Required	No

PRODUCT CERTIFICATIONS



ENERGY SPECS

Primary Energy Type	Electric
Electrical Total Amperage	12 A
Electrical Volts	230V
Electrical Total Wattage	3000 W
Electrical Kilowatts	3 kW
Electrical Phase	1-Phase

Electrical Plug Type	UK 3-Pin Plug
Number of Electrical Plugs	1
Electrical Connection Type	Cord and Plug
Number of Electrical Conductor Wires	1
Dedicated Circuit Required	No
Electrical Remarks	Single

ADDITIONAL SPECIFICATIONS

Construction Materials	Stainless Steel
Sink Capacity	10 l
Sink Sill Height	950 mm
Water Faucet Actuation Method	Foot Activated Infrared Operated
Water Temperature Control	Factory Set

BIDDING SPECIFICATIONS

Bidding Specifications Not Available.



IMC IMCLEAN MOBILE HAND WASH STATION WITH SPLASHBACK,
SOAP & PAPER TOWEL HOLDER - W 450MM - 3.0KW

MODEL: F63/501

TECHNICAL DRAWING

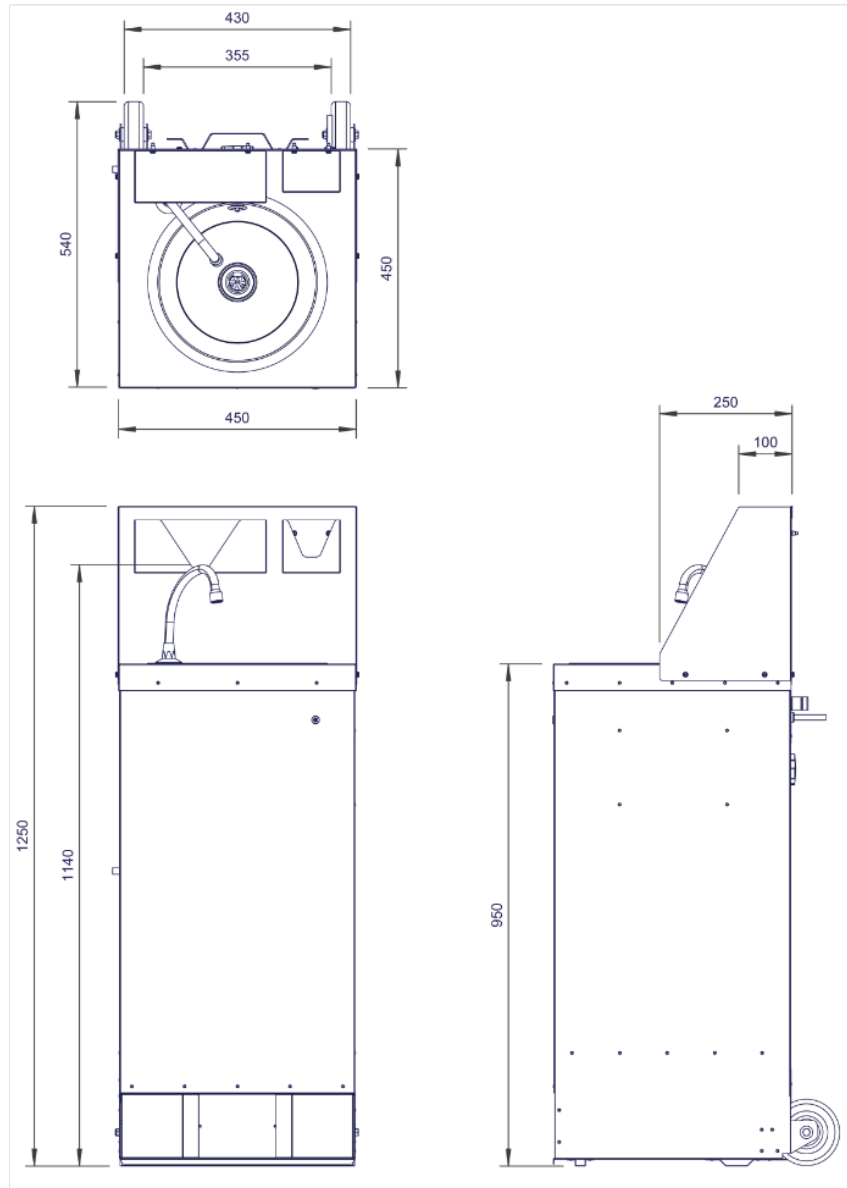

IMC reserves the right to modify specifications or discontinue models without incurring obligation. Dimensions nominal.

Document Auto-Generated
January 09, 2025