



**TRUE REFRIGERATION
INTERNATIONAL**

UK Tel +44 (0) 1709 888 080 • Germany Tel +49 (0) 7622 6883 0
Free Phone to U.S. 0 800 894 928 • www.truemfg.com



9/19

Model:
TUC-48-HC

Undercounter:
Solid Door Refrigerator with Hydrocarbon Refrigerant



TUC-48-HC

- ▶ True's undercounter units are designed with enduring quality that protects your long term investment.
- ▶ Designed using the highest quality materials and components to provide the user with colder product temperatures, lower utility costs, exceptional food safety and the best value in today's food service marketplace.
- ▶ Factory engineered, self-contained, capillary tube system using environmentally friendly R290 hydro carbon refrigerant that has zero (0) ozone depletion potential (ODP), & three (3) global warming potential (GWP).
- ▶ High capacity, factory balanced refrigeration system that maintains cabinet temperatures of 33°F to 38°F (.5°C to 3.3°C) for the best in food preservation.
- ▶ All stainless steel front, top and ends. Corrosion resistant GalFan coated steel back.
- ▶ Interior - attractive, NSF approved, clear coated aluminum liner. Stainless steel floor with coved corners.
- ▶ Front breathing.
- ▶ Heavy duty PVC coated wire shelves.
- ▶ Foamed-in-place using a high density, polyurethane insulation that has zero ozone depletion potential (ODP) and zero global warming potential (GWP).

ENERGIA - ENERGIJA - ENERGIJA
ENERGIJA - ENERGY - ENERGIJA
ENERGIJA

673
kWh/annum

247 L

5
40°C-40%

2015/1094

PLAN VIEW

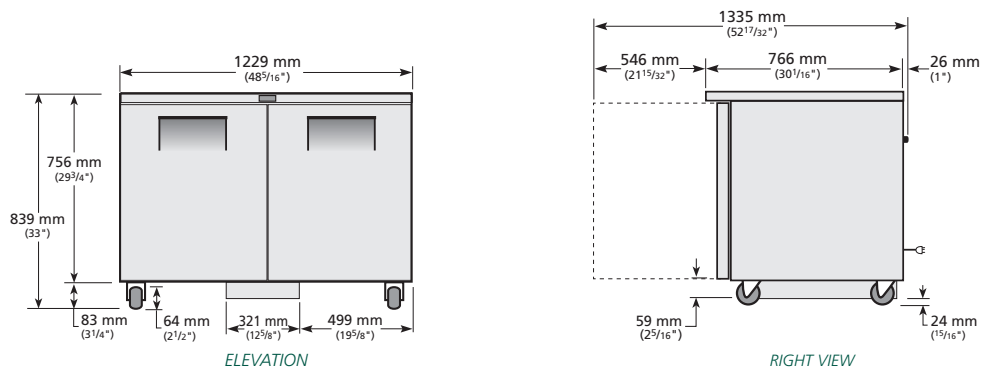

ROUGH-IN DATA

Specifications subject to change without notice.
Chart dimensions rounded up to the next whole millimeter (inches rounded up to the next 1/8").

Model	Model Type	Doors	Shelves	Cabinet Dimensions (mm)			Net Volume (litres)	EEC	EEI	24 hr/ Energy Consumption (kWh)	Annual Energy Consumption (kWh)	Crated Weight (kg)
				W	D†	H						
TUC-48-HC	Counter Chilled	2	4	1229	766	839	247	B	27.8	1.845	673	118

† Depth does not include 1" for rear bumpers.