

A
B
C
D
E
F

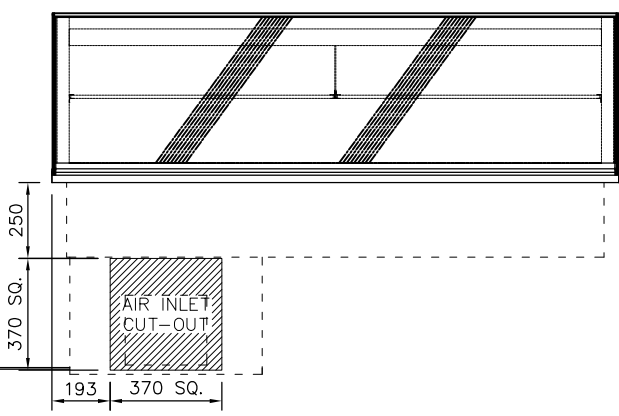

FRONT ELEVATION

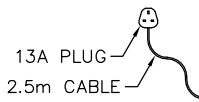
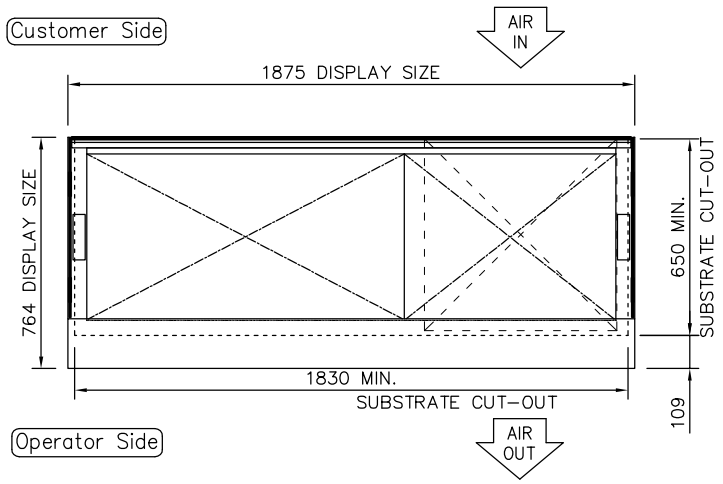

PLAN VIEW

NOTE:
IF DISPLAY IS TO BE FLUSH
MOUNTED INTO WORKTOP,
ADD 4 - 6mm TO DISPLAY
SIZES FOR WORKTOP CUT-OUT

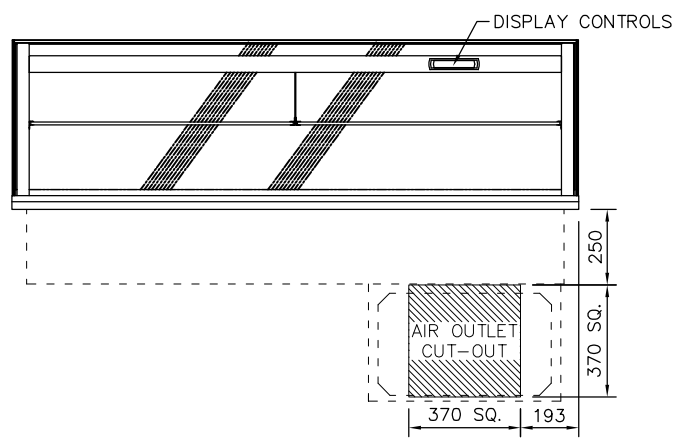
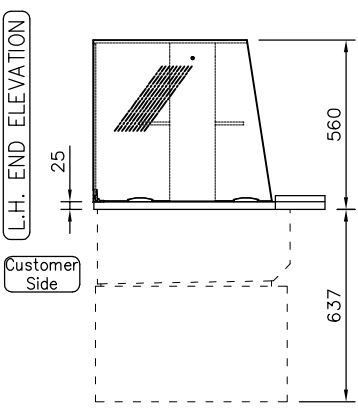

REAR ELEVATION



CUSTOMER & OPERATOR SIDE FASCIA
PANELS MUST BE REMOVABLE FOR
MAINTENANCE ACCESS

SUPPLIED WITH 400mm SQ. STAINLESS
STEEL AIR INLET/OUTLET GRILLES

PRODUCT RANGE:	MANHATTAN
DESC.:	5-1Gn ASSISTED SERVICE COLD DELI
OPTION:	INTEGRAL REFRIGERATION
ID CODE:	MCDL5-GO
OPTION CODE:	

counterline

RANDLES RD, KNOWSLEY BUSINESS PARK, MERSEYSIDE L34 9HZ.
Tel: 0151 548 2211 Fax: 0151 549 2179

ELECTRICAL INFO: 13A, 230V, 2.3KW		WEIGHT: 183Kg
ISSUE:	1	SCALE: 1:25 @ A4