



TRUE EUROPE

Field's End Road, Goldthorpe, Nr. Rotherham, South Yorkshire S63 9EU, UK
 www.truemfg.com • Tel +44 01709 888 080 • Fax +44 01709 880 838
 Free Phone 0 800 783 2049 • Free Phone to U.S. 0 800 894 928



12/15

Model:
TAC-27K-HC-LD

Vertical Air Curtains:
 Refrigerator with Hydrocarbon Refrigerant & LED Lighting



TAC-27K-HC-LD

- ▶ True's air curtain merchandisers are designed with enduring quality that protects your long term investment.
- ▶ Designed using the highest quality materials and components to provide the user with colder product temperatures and lower utility costs in an attractive merchandiser that brilliantly displays food and beverages.
- ▶ Factory engineered, self-contained, capillary tube system using environmentally friendly R290 hydro carbon refrigerant that has zero (0) ozone depletion potential (ODP), & three (3) global warming potential (GWP).
- ▶ Large, open front allows easy access to display levels and places maximum attention on merchandising.
- ▶ Oversized, factory balanced, refrigeration system holds 33°F to 38°F (.5°C to 3.3°C).
- ▶ Patented reversing condenser fan motors. Fan motors reverse during defrost off cycles to help keep condenser coil free from dirt, dust and debris. Keeping coils clean optimizes the unit's performance providing colder holding temperatures and increased energy efficiency. Regularly scheduled thorough cleaning of coils still recommended.
- ▶ Attractive and durable clear aluminum exterior and interior with stainless steel floor and deck pans.
- ▶ Adjustable, heavy duty chrome plated wire shelves.
- ▶ 47 mm (1 13/16") diameter dual swivel castors.
- ▶ Entire cabinet structure is foamed-in-place using a high density, polyurethane insulation that has zero ozone depletion potential (ODP) and zero global warming potential (GWP).

PLAN VIEW

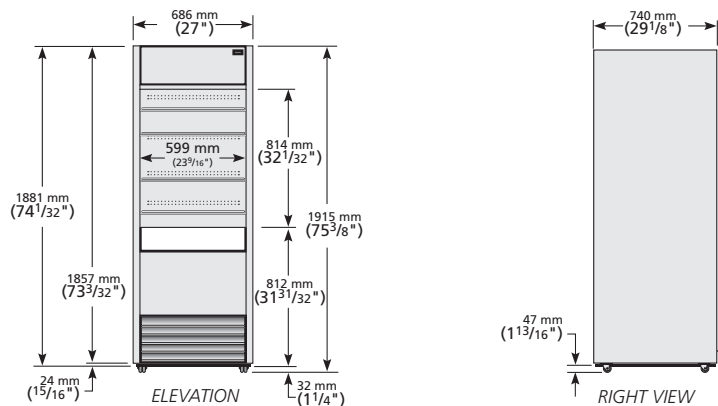

ROUGH-IN DATA

Specifications subject to change without notice.
 Chart dimensions rounded up to the next whole millimeter (inches rounded up to the next 1/8").

| Model | Shelves | Cabinet Dimensions (mm) | | | HP | Voltage | Amps | NEMA Config. | Cord Length (total m) | Crated Weight (kg) |
|---------------|---------|-------------------------|-----|------|-------|--------------|------|--------------|-----------------------|--------------------|
| | | L | D | H | | | | | | |
| TAC-27K-HC-LD | 4 | 686 | 740 | 1915 | 1/2 + | 230-240/50/1 | 4.4 | ▲ | 1.98 | 152 |

▲ Plug type varies by country.