



C6A/100S - Lincat Seal 650 Series Counter-top Curved Front Ambient Merchandiser - Self- Service - W 1000 mm - 0.02 kW

Display your pastries, breads and cakes with pride with the Seal 650 Range Curved Front Ambient Merchandiser.

- ✓ Understated elegant curved design with extruded aluminium frames and metallic silver finish, which enhances display without detracting from the contents
- ✓ Sleek design and chrome plated rod shelves are attractive and easy to clean
- ✓ All-round visibility to maximise food sales potential
- ✓ Suitable for self-service applications
- ✓ Provides daylight balanced illumination, which lights up the units interior and spotlights each product
- ✓ This products design ensures a smooth fit alongside other refrigerated, ambient and heated units

Specifications

Summary

Brand	Lincat
Range	Seal
Series	650 Series
Power Type	Electric
Unit Type	Counter-top
Available in UK Only	No
UK Warranty	2 Years Parts and Labour Warranty
Export Warranty	Contact your local dealer
GTIN	5056105103806

Power and Performance

Total Power kW	0.02
IP Rating	IP33

Key Specifications

Number of Shelves included	2
Number of Shelf Positions	2
Service Type	Self service
Rack Type	Static
Type of Lighting	Fluorescent

Weights and Dimensions

Unit Height (External) mm	755
Unit Width (External) mm	1000
Unit Depth (External) mm	650
Shelf Dimensions Width mm	900
Shelf Dimensions Depth mm	525
Net Weight Kg	54.4

Supply Connections

Requires Installation	No
Requires Electrical Supply	Yes
UK 3 Pin Plug	Yes
Requires Hardwiring	No
Electrical Supply Rating Watts	20
Single Phase Amps	<1.0
Single Phase Voltage	230

Shipping

Packed Weight Kg	59.84
Packed Height cm	90
Packed Width cm	115
Packed Depth cm	75

Technical Picture

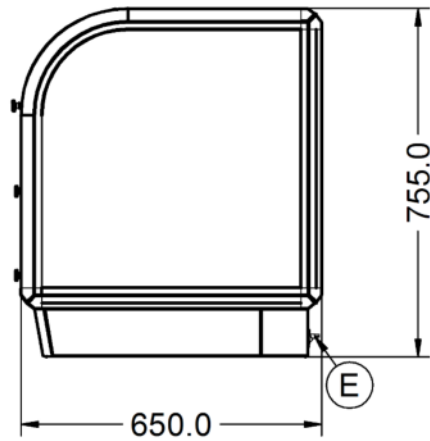
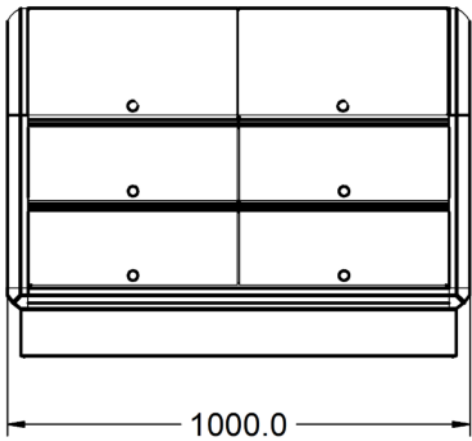
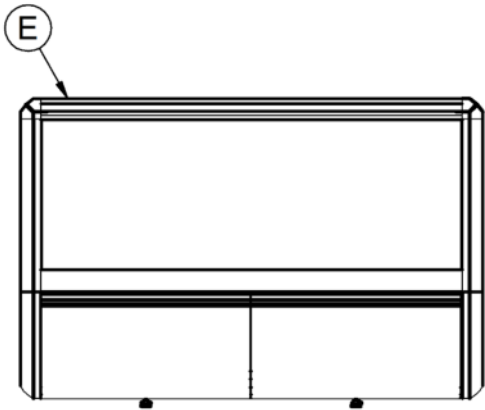

Lincat Limited

Whisby Road,
Lincoln, LN6 3QZ,
United Kingdom

Company No: 2175448

A member company of



Customer Care

Tel: +44 1522 875500
Email: care@lincat.co.uk

Export Customers

Tel: +44 1522 875536
Email: export@lincat.co.uk

Opening Hours

Monday – Friday:
8.30am – 5pm