

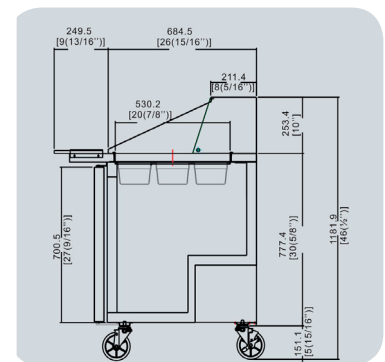

STV1530MT Mega Top Preparation Counter Refrigerator

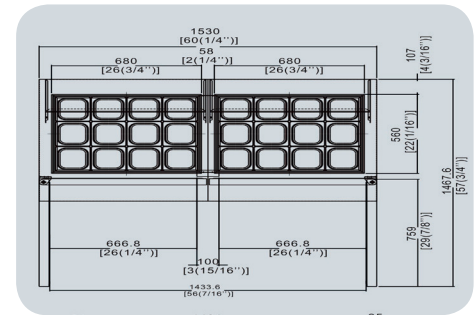

Description

Designed to maximise salad, sandwich and pizza preparation. 2 x 2/1 GN sections for food separation
Very useful dual zone top that will accept 1/3, 1/2 and 1/4 GN pans preserves meats, dairy and
and general produce.

Star Features

- Forced air cooling top
- 24 GN1/6 pans not included
- Large cutting board
- Excellent understorage
- Insulated top lids
- Ventilated cooling
- Quality stainless
- Auto defrost
- Swivel castors - heavy duty
- Big storage doors
- 2 Adjustable shelves
- Easy fit door seals

Technical Specification

| | |
|-------------------|------------------------|
| Model | STV1530MT Prep Counter |
| Dimensions | W1530 x D863 x H1183 |
| Temperature Range | +1°C to +8°C |
| Capacity Nett | 526 Litres |
| Compressor | EMBRACO EGU130HLR |
| Refrigerant | R134a |
| Power | 13Amp Plug |
| Nett Weight | 160Kg |
| Shipping Weight | 174Kg |

