



J18 - Lincat Silverlink 600 Electric Free-standing Twin Tank Fryer - 2 Baskets - W 600 mm - 2 x 9.0 kW

Deliver perfectly crisp on the outside and fluffy on the inside chips time after time with the Silverlink 600 Free Standing Electric Fryer.

- ✔ Two independently operated fryer tanks for greater versatility, increased power delivers 60kg of chips per hour
- ✔ Front mounted controls for safety
- ✔ Hinged elements to give easy access during cleaning
- ✔ Cool zone collects cooking debris - gives cleaner cooking results and saves money by prolonging the life of the oil
- ✔ Thermostatically controlled to give accurate cooking temperatures throughout cooking. Flame failure device and top temperature cut out ensures safe operation.
- ✔ Fully moulded 304 stainless steel tank and heavy duty nickel plated baskets for the most demanding of operations
- ✔ Front drain off tap for easy removal of cooking oil

Specifications

Summary

Brand	Lincat
Range	Silverlink 600
Power Type	Electric
Unit Type	Free-standing
Available in UK Only	No
UK Warranty	2 Years Parts and Labour Warranty
Export Warranty	Contact your local dealer
GTIN	5056105105114

Power and Performance

Total Power kW	2 x 9.0
Temperature Range °C	130-190
IP Rating	IP34
Temperature Control	Mechanical

Key Specifications

Number of Baskets	2
Number of Tanks	2
Gravity Filtration	No
Pumped Filtration	No
Drain Location	Front-mounted

Capacity

Product Output per Hour	52kg chips -12mm [frozen], 60kg chips - 12mm [chil]
Capacity Litres	2 x 9.0

Weights and Dimensions

Unit Height (External) mm	980
Unit Width (External) mm	600
Unit Depth (External) mm	632
Net Weight Kg	45

Supply Connections

Requires Installation	Yes
Requires Electrical Supply	Yes
UK 3 Pin Plug	No
Requires Hardwiring	Yes
Electrical Supply Rating Watts	2 x 9,000
Single Phase Amps	2 x 39.0
Single Phase Voltage	230
Three Phase Amps	L1=2 x 13.0; L2=2 x 13.0; L3=2 x 13.0
Three Phase Voltage	400

Shipping

Packed Weight Kg	55
Packed Height cm	110
Packed Width cm	78
Packed Depth cm	78

Available Accessories

BA96	BASKET SPUN DFSMALL
ST10	NULL
TA28	NULL

Technical Picture

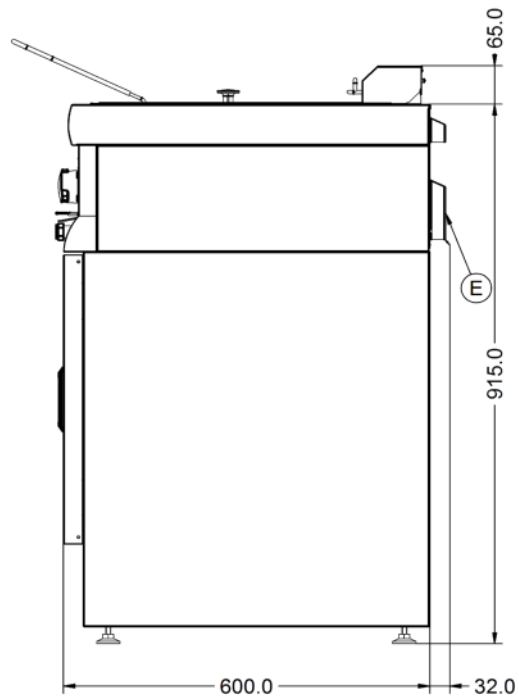
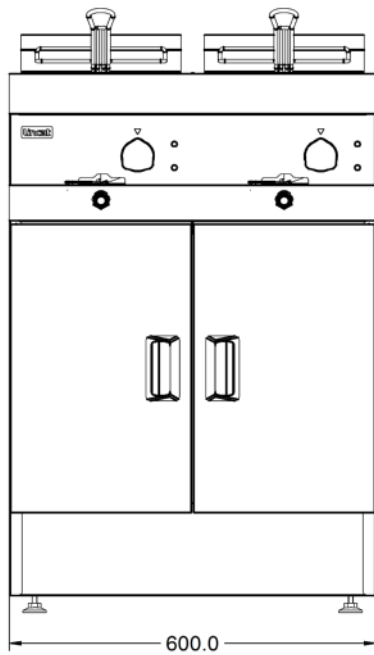
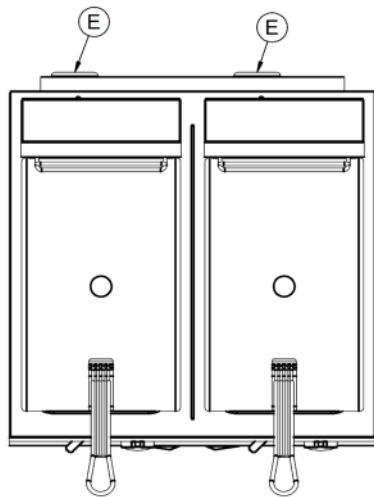



Lincat Limited

Whisby Road,
Lincoln, LN6 3QZ,
United Kingdom

Company No: 2175448

A member company of



Customer Care

Tel: +44 1522 875500
Email: care@lincat.co.uk

Export Customers

Tel: +44 1522 875536
Email: export@lincat.co.uk

Opening Hours

Monday – Friday:
8.30am – 5pm