



D5R/100S - Lincat Seal 500 Series Counter-top Refrigerated Merchandiser - Self- Service - W 1000 mm - 0.6 kW

Make maximum use of limited space with the Seal 500 Range Refrigerated Merchandiser's generous capacity.

- ✓ Using precise thermostatic control this unit holds food from 3°C - 7°C. It enables the user to accurately monitor the temperature of product for the absolute best results
- ✓ Digital display which gives clear indication of temperature to the user
- ✓ The unit is double glazed which keeps the cool air locked in, this in turn gives the customer better results while also saving money through energy efficiency.
- ✓ Provides daylight balanced illumination, which lights up the units interior and spotlights each product
- ✓ Options for self service or back service are also available.
- ✓ Spacious unit enabling you to showcase a wide variety of product

Specifications

Summary

Brand	Lincat
Range	Seal
Series	500 Series
Power Type	Electric
Unit Type	Counter-top
Available in UK Only	No
UK Warranty	2 Years Parts and Labour Warranty
Export Warranty	Contact your local dealer
GTIN	5056105104087

Power and Performance

Total Power kW	0.600
Temperature Range °C	3-7
IP Rating	IP33
Temperature Control	Electronic

Key Specifications

Number of Shelves included	1
Number of Shelf Positions	1
Refrigerant Type	R452a
Service Type	Self service
Type of Lighting	Fluorescent

Weights and Dimensions

Unit Height (External) mm	575
Unit Width (External) mm	1000
Unit Depth (External) mm	500
Height (Internal) mm	362
Width (Internal) mm	660
Depth (Internal) mm	424
Shelf Dimensions Width mm	650
Shelf Dimensions Depth mm	375
Net Weight Kg	70

Supply Connections

Requires Installation	No
Requires Electrical Supply	Yes
UK 3 Pin Plug	Yes
Requires Hardwiring	No
Electrical Supply Rating Watts	602
Single Phase Amps	2.60
Single Phase Voltage	230

Shipping

Packed Weight Kg	83.5
Packed Height cm	89
Packed Width cm	115
Packed Depth cm	75

Technical Picture

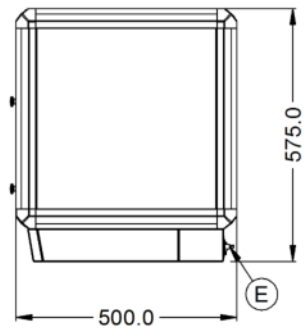
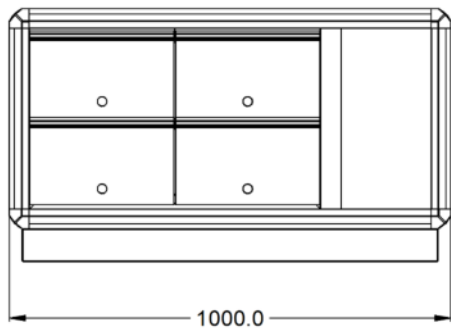
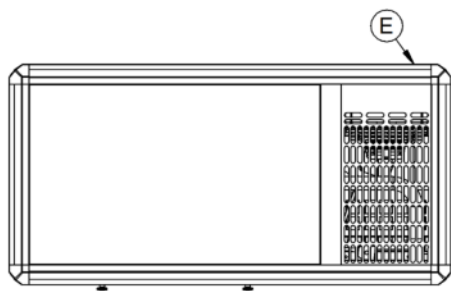



Lincat Limited

Whisby Road,
Lincoln, LN6 3QZ,
United Kingdom

Company No: 2175448

A member company of



Customer Care

Tel: +44 1522 875500
Email: care@lincat.co.uk

Export Customers

Tel: +44 1522 875536
Email: export@lincat.co.uk

Opening Hours

Monday – Friday:
8.30am – 5pm